

# OWNER'S GUIDE

## ADVANCED REVERSE OSMOSIS WATER TREATMENT SYSTEMS

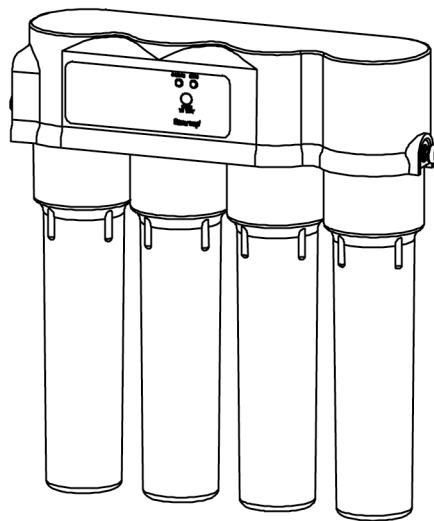

MODEL SERIES 12403



WQA Tested and Certified against  
CSA B483.1:  
4VTFC09G-PB    4VTFC50G-PB  
4VTFC25G-PB    4VTFC75G-PB



These models are tested and certified by  
WQA against NSF/ANSI 58 for the  
reduction of TDS. Tested and Certified by  
WQA against ORD0902 for "lead free"  
compliance.  
4VTFC09G-PB    4VTFC50G-PB  
4VTFC25G-PB    4VTFC75G-PB

**Please fill in the following information and retain for reference:**

Unit Model Number: \_\_\_\_\_

Serial Number: \_\_\_\_\_

Date Purchased: \_\_\_\_\_

Date Installed: \_\_\_\_\_

## INTRODUCTION

Congratulations, on the purchase of your new Advanced Reverse Osmosis Water Treatment System. Treated with care and regular maintenance, your new system will provide many years of service delivering great tasting water to the tap.

By now, you have probably already opened the box to survey the contents. Please take a few moments to review this manual before proceeding with the installation and use of the system. Some important items to review are as follows:

- Check all components for any damage caused in shipment. Also, take a quick inventory of all items supplied to ensure none are missing. A checklist in the next section will assist you with identifying these items.
- Ensure that the reverse osmosis system and storage tank will easily fit into the desired location. This reverse osmosis system and tank needs to be removed for regular maintenance, so good accessibility is an important tip to keep in mind.
- Read all **CAUTIONS** and **NOTES** contained within this manual. They provide valuable installation tips and advice on how to properly install and maintain your Reverse Osmosis Drinking Water System.
- **For installation in Massachusetts, the Massachusetts Plumbing Code 248 CMR shall be adhered to. Consult your licensed plumber for installation of this system. The use of saddle (piercing) valves is not permitted.**

The water produced by the reverse osmosis (RO) process can be used for many purposes around the home.

- **Drinking Water** - keep a container of RO water in the fridge to be able to enjoy the clean, fresh taste. Alternatively, take it directly from the tap.
- **Ice Cubes** - use RO water to fill ice cube trays. Ice cubes made from RO water are typically clearer and better tasting than ice made from tap water.
- **Automatic Ice Makers** - a water line from the RO system can be plumbed to refrigerators with automatic icemakers. Additional accessories required to complete this connection are not included. Please consult the refrigerator's owner's manual on this installation.
- **Kettles and Coffee Makers** - tap water eventually causes films and scale in these devices that is difficult to clean. RO water is very low in dissolved minerals content, greatly reducing the chance of scale buildup.
- **Cooking** - use RO water for boiling pasta, rice or any other recipe that calls for water.
- **Washing Fresh Fruit & Vegetables** - prevent tap water minerals from being deposited onto food to maintain freshness.
- **Family Pets** – Allow your pets to enjoy the same great tasting water you do.
- **Irons & Steamers** - prevent mineral buildup in household appliances that use water and eventually build up with scale when using tap water.

Now you can enjoy all the benefits of great tasting water supplied by your reverse osmosis drinking water system.

## CERTIFIED CONTAMINANT REDUCTION PERFORMANCE



Models 4VTFC09G-PB, 4VTFC25G-PB, 4VTFC50G-PB and 4VTFC75G-PB are tested and certified by WQA against NSF/ANSI 58 for the reduction of TDS. Tested and Certified by WQA against ORD0902 for "lead free" compliance.



WQA Tested and Certified against CSA B483.1

C

The following 12403 Series Reverse Osmosis Systems conform to NSF/ANSI 58 for the specific performance claims as verified and substantiated by test data.

### MODELS AND SYSTEM CONFIGURATIONS

**Table 1**

Model Description	Storage Tank	# of Vessels	Storage Tank Capacity Litres (gal)	Vessel 1	Vessel 2	Vessel 3	Vessel 4	Daily Production Rate <sup>(2)</sup> L/day (G/day)	Efficiency Rating <sup>(3)</sup> %	Recovery Rating <sup>(4)</sup> %	Monitor <sup>(6)</sup>
4VTFC09G-PB	Plastic/Metal	4	6.81 (1.8)	Sediment Filter	Carbon Filter	TFC <sup>(1)</sup> Membrane	Carbon Filter	15.5 (4.1)	12.8	35	Smartap® Push Button
4VTFC25G-PB	Plastic/Metal	4	7.19 (1.9)	Sediment Filter	Carbon Filter	TFC <sup>(1)</sup> Membrane	Carbon Filter	29.1 (7.7)	8.2	18	
4VTFC50G-PB	Plastic/Metal	4	6.81 (1.8)	Sediment Filter	Carbon Filter	TFC <sup>(1)</sup> Membrane	Carbon Filter	34.44 (9.1)	4.8	16.7	
4VTFC75G-PB	Plastic/Metal	4	7.19 (1.9)	Sediment Filter	Carbon Filter	TFC <sup>(1)</sup> Membrane	Carbon Filter	49.58 (13.1)	5.7	15.3	

### CONDITIONS FOR USE

**Table 2**

Source Water Supply Profile		Chemical Parameters	Max mg/L
Community/Private	Chlorinated/Non-Chlorinated	Hardness (CaCO <sub>3</sub> )	<350 (20 gpg)
Feed Water Pressure <sup>(5)</sup>	242-690 kPa (35-100 psig)	Iron (Fe)	<0.1
Temperature	4°-38° C (40°-100° F)	Manganese (Mn)	<0.05
pH Range	3.0 - 11.0	Hydrogen Sulfide (H <sub>2</sub> S)	0.00
Maximum TDS Level	2000 mg/L	Residual Chlorine (Cl <sub>2</sub> )	<2.0
Turbidity**	<1.0 NTU	** Nephelometric Turbidity Unit	
Maximum SDI***	<4.0	*** Silt Density Index: Value stated in SDI units.	

- NOTES:
1. TFC refers to reverse osmosis membranes constructed from a THIN FILM COMPOSITE
  2. The daily production rate is the volume of product water produced by the system per day and is determined by testing in accordance with the procedure outlined in NSF/ANSI Standard 58.
  3. System's Efficiency rating as verified by testing in accordance with NSF/ANSI standard 58. Efficiency rating means the percentage of the influent water to the system that is available to the user as reverse osmosis treated water under operating conditions that approximate typical daily usage.
  4. System's Recovery rating as verified by testing in accordance with NSF/ANSI Standard 58. System's Recovery rating means the percentage of the influent water to the membrane portion of the system that is available to the user as reverse osmosis treated water when the system is operated without a storage tank or when the storage tank is bypassed.
  5. PRESSURE REGULATOR IS RECOMMENDED FOR FEED WATER PRESSURES EXCEEDING 552 kPa (80 psig)
  6. SMARTAP® PUSH BUTTON MONITOR. Indicator lights located on the module cover report system status.

### OPTIONS AND ACCESSORIES

PRODUCT WATER FAUCETS	BOOSTER PUMP
Faucets will be supplied as Air Gap.	A booster pump may be used if system pressure is below 242 kPa (35 psi). Pump should be placed near RO Module and installed in feed water line just before it enters Module.

## GENERAL INFORMATION

This Owner's Guide covers all components that may be included with a system. Information relating to any component that is NOT included with your system may be disregarded.

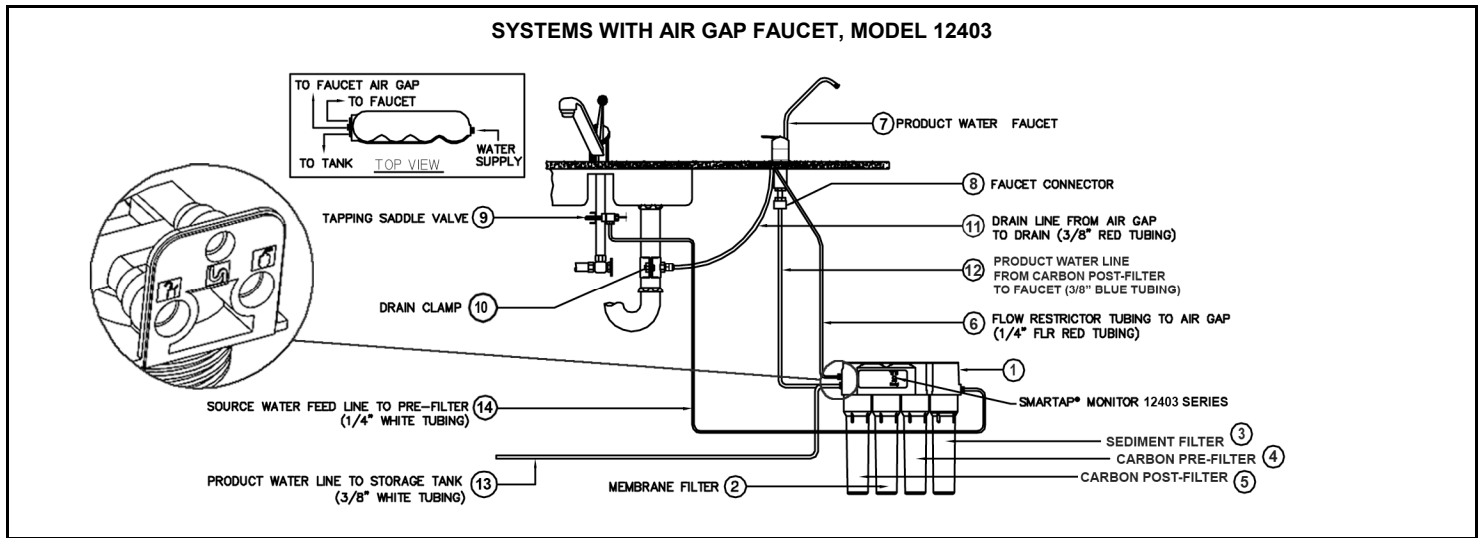

REVERSE OSMOSIS SYSTEM		
Item	Description	Part No.
1	4 Vessel Module, With Quality Monitor	Fig 8
MEMBRANE AND FILTERS		
2	Reverse Osmosis TFC Membrane	
	9 GPD, Yellow Casing, Red Tape	33001071
	25 GPD, Yellow Casing, Black Tape	33001068
	50 GPD, Yellow Casing, White Tape	33001033
3	75 GPD, Yellow Casing, Blue Tape	33001056
	Sediment Filter	41400008
4	Carbon Pre-Filter	41400009
5	Carbon Post Filter	41400009
FLOW RESTRICTOR TUBING		
6	Flow Restrictor Tubing	
	9 GPD	40600034
	25 GPD	40600040
	50 GPD	40600041
	75 GPD	40600042

PRODUCT WATER FAUCETS		
Item	Description	Part No.
7	Chrome-Plated Metal, Air Gap	92192, Fig 7
8	Connector, Faucet 3/8" x 7/16"	92407
INSTALLATION KIT		
	<b>Complete Kit</b>	
9	Supply Valve, Saddle-Tapping	92276
10	Drain Clamp, Saddle Clamp, Air Gap, 3/8"	92160
11	Tubing, 3/8", Red	87604
12	Tubing, 3/8", Blue	87600
13	Tubing, 3/8", White	115207
14	Tubing, 1/4", White	115200
n/s	Screw, Mounting Bracket (2 each)	32701006
n/s	Elbow, Stem, 3/8" (2 each)	33501071
n/s	Elbow, Stem 1/4" (2 each)	33501064
n/s	Owner's Guide	36101291
n/s	Kit, O-Rings, Collets, QC 1/4" & 3/8"	92166
n/s	Safety Clip 1/4"	96345
n/s	Safety Clip 3/8"	92346

n/s - not shown

Figure 1.A: Component\* and Interconnection Locators, Model 12403.

\*Replacement parts can be obtained from your local dealer. Refer to your local dealer stamp at the back page of this manual.

## GENERAL INFORMATION

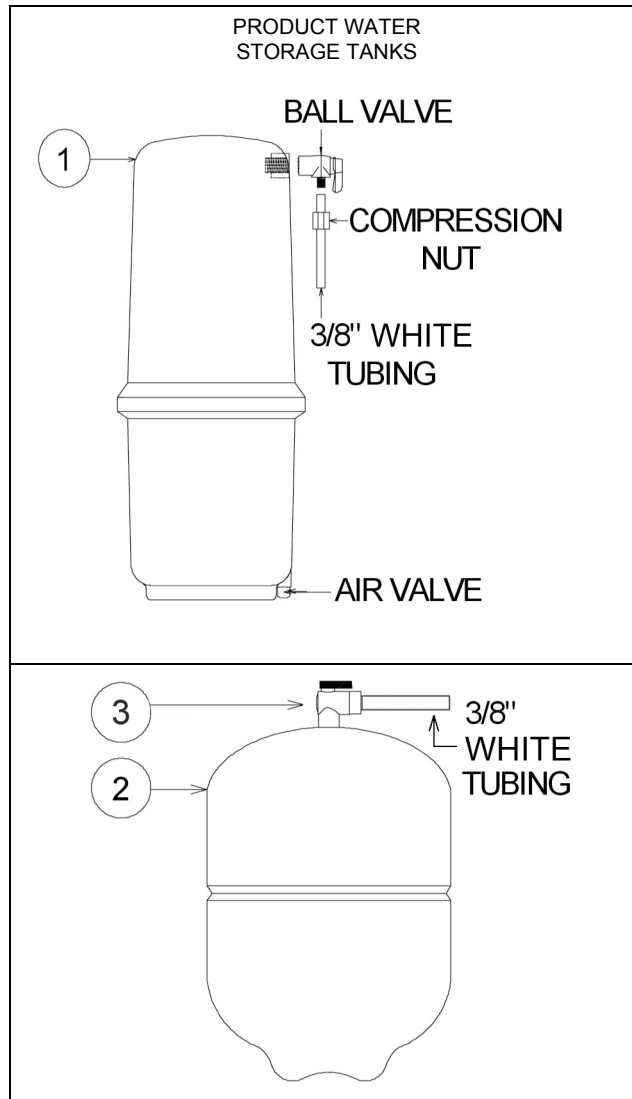

PRODUCT WATER STORAGE TANKS - ALL SYSTEMS		
Item	Description	Part No.
1	Storage Tank Assembly, Polymer	92313
2	Storage Tank Assembly, Metal	92342/92294
3	Ball Valve, 3/8"	33503601

**Figure 1.B:** Product Water Storage Tanks.

# INSTALLATION REQUIREMENTS

## READ THIS ENTIRE INSTALLATION AND SERVICE GUIDE BEFORE BEGINNING INSTALLATION

The 12403 Series Reverse Osmosis (RO) Drinking Water Treatment Systems have been designed for ease of installation and serviceability and are constructed with the finest materials available. Using these instructions and paying close attention to the parameters outlined within "CONDITIONS FOR USE" detailed on Page II will ensure a successful installation.

**All systems must be installed in accordance with applicable city, state, provincial and local plumbing codes. For installation in Massachusetts, the Massachusetts Plumbing Code 248 CMR shall be adhered to. Consult your licensed plumber for installation of this system. The use of saddle (piercing) valves is not permitted.** To ensure a system continues to operate at its optimum level, it is necessary to have a routine maintenance and replacement schedule (Table 4). Frequency at which filters must be changed will depend on quality of feed water supply and level of system usage.

**These RO systems contain a replaceable treatment component critical to the efficiency of the system. Replacement of the reverse osmosis component should be with one of identical specification, as defined by WaterGroup to assure the same efficiency. Product water shall be tested periodically to verify the system is performing properly. Operator performs test using the optional Smartap® Water Quality Monitor.**

**All state, provincial and local government codes regarding installation of these devices must be observed.**

### PREPARATION

1. Check that all appropriate components are packed with your system (Figures 1.A. and 1.B.).
2. Determine locations for RO component installation. Two requirements for consideration are: access to cold water supply line and household sink drainpipe. Specific requirements are detailed in Table 3.

### COMPONENT LOCATION REQUIREMENTS

**Table 3**

<b>PRODUCT WATER FAUCET</b> Faucet may be installed in any convenient location. Make sure underside of location is free of obstructions.	<b>REVERSE OSMOSIS MODULE</b> Module may be installed under sink or in any convenient location within 15 feet of source water supply and faucet.
<b>STORAGE TANK</b> Tank may be placed in any space within 15 feet of faucet, generally under kitchen sink or in an adjacent unused cabinet. Tubing length between components should be kept to a minimum, avoiding sharp bends or kinks.	
<b>DO NOT PLACE MODULE WHERE IT WILL BE EXPOSED TO FREEZING AND/OR DIRECT SUNLIGHT. MODULE MUST BE EASILY REMOVABLE FOR PERFORMANCE OF ROUTINE MAINTENANCE.</b> Mount Module on side of cabinet using bracket (attached to Module) and two screws provided in the Installation Kit. <b>HOLD THE MODULE BY THE FILTER HOUSINGS WHEN PICKING UP OR CARRYING UNIT.</b>	

### NOTE

THIS DRINKING WATER SYSTEM IS FOR USE ON POTABLE WATER SUPPLIES ONLY. SOURCE WATER EXCEEDING CHEMICAL PARAMETERS REQUIRES PRE-TREATMENT.

### CAUTION

**DO NOT USE WITH WATER THAT IS MICROBIOLOGICALLY UNSAFE OR OF UNKNOWN QUALITY WITHOUT ADEQUATE DISINFECTION BEFORE OR AFTER THE SYSTEM.**

### MAINTENANCE REQUIREMENTS

**Table 4**

Service Requirements	Recommended Service Intervals
To insure the system operates at its optimum level, certain routine maintenance must be performed. Frequency of maintenance performance will depend on feed water quality and level of system usage.  <b>CLEAN:</b> Each time filters are replaced <b>SANITIZE:</b> At least once a year and each time membrane is replaced	Replace filters as required or every 6 to 12 months depending on feed water quality.  Replace membrane as required based on Smartap® Water Quality Monitor indication or periodic TDS rejection tests.  Maximum recommended service life for membrane is 60 months.

## PERFORMANCE INDICATORS

### OPTIONAL SMARTAP® WATER QUALITY MONITOR

WaterGroup's 12403 Series Reverse Osmosis Systems incorporate a proven performance indicator. Our *patented* Smartap® Water Quality Monitor uses dual probe LOGIC PULSE MEMORY technology to accurately indicate membrane performance. A split-second power pulse compares feed water Total Dissolved Solids (TDS) level with that of the product water. Then, by reversing the polarity of the electronic pulse, the probes are cleaned and kept free of chemical plating. A nine-volt alkaline battery provides power to the Monitor. For optimum monitor performance, the battery should be replaced each time system is sanitized.

**NOTE:** Monitor Troubleshooting Indicators and Common Solutions are shown in Table 5 on Page 13.

#### Push Button Actuated Smartap® - 12403 Series

Pressing a test button located on the manifold cover activates monitor. When button is pressed, and momentarily held down, monitor reports membrane status by illuminating a light located next to test button. A green light means system is operating normally. A yellow light indicates system needs servicing (membrane may be depleted or fouled). While the button may be pressed at any time, the most accurate readings are obtained when the system is making water for at least 10 minutes.

The customer can also contact the local dealer for water sampling service or kit.

## INTER-COMPONENT CONNECTIONS

Connections between cold water supply line, RO Module, storage tank, product water faucet, and drain line are accomplished using plastic tubing and push-together quick-connect type fittings.

### PLASTIC TUBING

1. Cut tube ends square and straight. Do not deform tube (i.e., cause tube to compress its diameter so it is no longer round).
2. Make sure outer surface of tube is clear of marks or scratches for a length equal to twice tube diameter. This allows "O" ring to seat properly against tube.
3. Avoid sharp changes in direction when routing tubing. Sharp turns cause tubing to flex and deform, which reduces its flow capacity and may increase lateral stress on the fittings, causing leakage.

### QUICK-CONNECT FITTINGS

Fittings consist of two parts: a Body and a colored collet and symbol. Collet color and symbol corresponds to tubing to be used at that connection (Figure 2.A.).

1. To install a tube, push it through Collet until it seats firmly at bottom of fitting (Figure 2.A and 2.B.).
2. To remove a tube, push and hold Collet against Body while pulling tube out (Figure 2.C.).

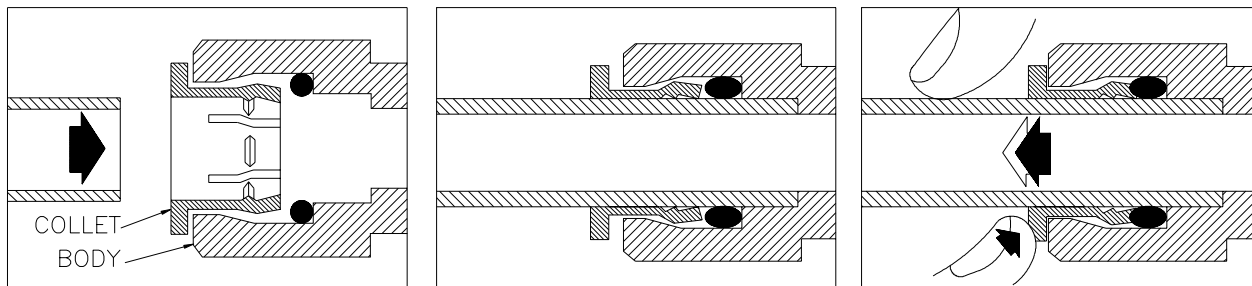

A. Push tube through Collet into Body.

B. Tube must seat firmly at bottom of fitting.

C. Push Collet against Body to release tube.

**Figure 2:** How to Use Quick-Connect Fittings

## SADDLE-TAPPING VALVE INSTALLATION ON COPPER TUBE

**CAUTION:** This saddle-tapping valve is not designed for installation on flex line tubing.

**NOTE:** For installation in Massachusetts, the Massachusetts Plumbing Code 248 CMR shall be adhered to. Consult your licensed plumber for installation of this system. The use of saddle (piercing) valves is not permitted.

1. **CAUTION:** If no shut off valve is installed under sink, close main water valve during this Installation.

Locate shut off valves on water lines under sink. To identify hot supply pipe and cold supply pipe, turn both faucets on and let water run. As water flows, hot water pipe becomes noticeably warmer.

2. **CAUTION:** Do not install feed water assembly on hot water line.

Turn off cold water supply by closing shut off valve. Drain line by opening sink faucet. Some mixing type faucets may require hot water supply be shut off as well.

**NOTE:** All instructions refer to components shown in Figure 3 unless otherwise noted.

3. **CAUTION:** Do not turn valve handle before or while installing saddle-tapping valve. Make sure piercing lance does not protrude beyond rubber gasket before installing valve.

Assemble saddle-tapping valve assembly on tube.

- a. Hold back plate against tube.
  - 3/8" copper tubing use back plate smaller radius.
  - 1/2" copper tubing, use back plate larger radius
- b. Hold valve saddle against tubing in a position directly opposite back plate.
- c. Tighten screw enough so valve saddle and back plate are held securely against tube.
- d. Rotate assembly so tubing connection is aligned toward RO Module feed port.
- e. Tighten screw firmly. Do not crush tube.

4. Connect source water feed tubing to valve body using compression fitting.
  - a. Slide nut and sleeve onto tubing (in that order).
  - b. Install insert into plastic tubing.
  - c. Install tube with insert and sleeve into valve body.
  - d. Thread compression nut onto valve body, tighten.
5. Turn saddle-tapping valve handle clockwise until it is firmly seated and piercing lance is fully extended.
6. **CAUTION:** Supply line is pierced and valve is closed. Do not open valve until system is activated (Page 9).

Turn on cold water supply. Check saddle-tapping valve installation for leaks. Allow water to run from faucet for a few minutes to clear any debris in the line caused by installation.

**NOTE:** If flow from sink faucet is reduced, clean faucet aerator.

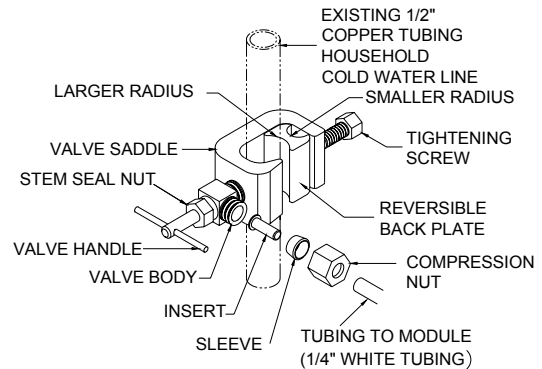

**Figure 3:** Saddle-Tapping Valve Assembly P/N 92276 installed on 1/2" Copper Tubing

7. Trim 1/4" white tube to desired length. Install 1/4" white tube into 1/4" white collet as shown in Figure 1.A.

## ADDITIONAL POINT OF USE CONNECTION

**NOTE:** Ice makers typically use 1/4" tubing as feed line. Use a reducing union (P/N 92402) for this connection.

**NOTE:** Reduce the 3/8" Line to 1/4" as close as possible to the additional point-of-use device to minimize flow loss.

1. To connect an additional point of use (icemaker, extra faucet in wet bar and/or another use for treated water), place a "tee" connector (P/N 92403) in 3/8" blue line between faucet and RO Module.
2. Connect "tee" to point-of-use with 3/8" blue tubing (P/N 87600). Connect tubing to point-of-use. Connector requirements are based on type of delivery device i.e., a typical icemaker uses 3/8" x 1/4" reducing device.

## DRAIN OUTLET ASSEMBLY INSTALLATION

**NOTE:** State, provincial and local plumbing codes may prohibit use of saddle-tapping drain connections and may require use of an air gap.

**NOTE:** Location and orientation of drain outlet assembly is vital to system performance.

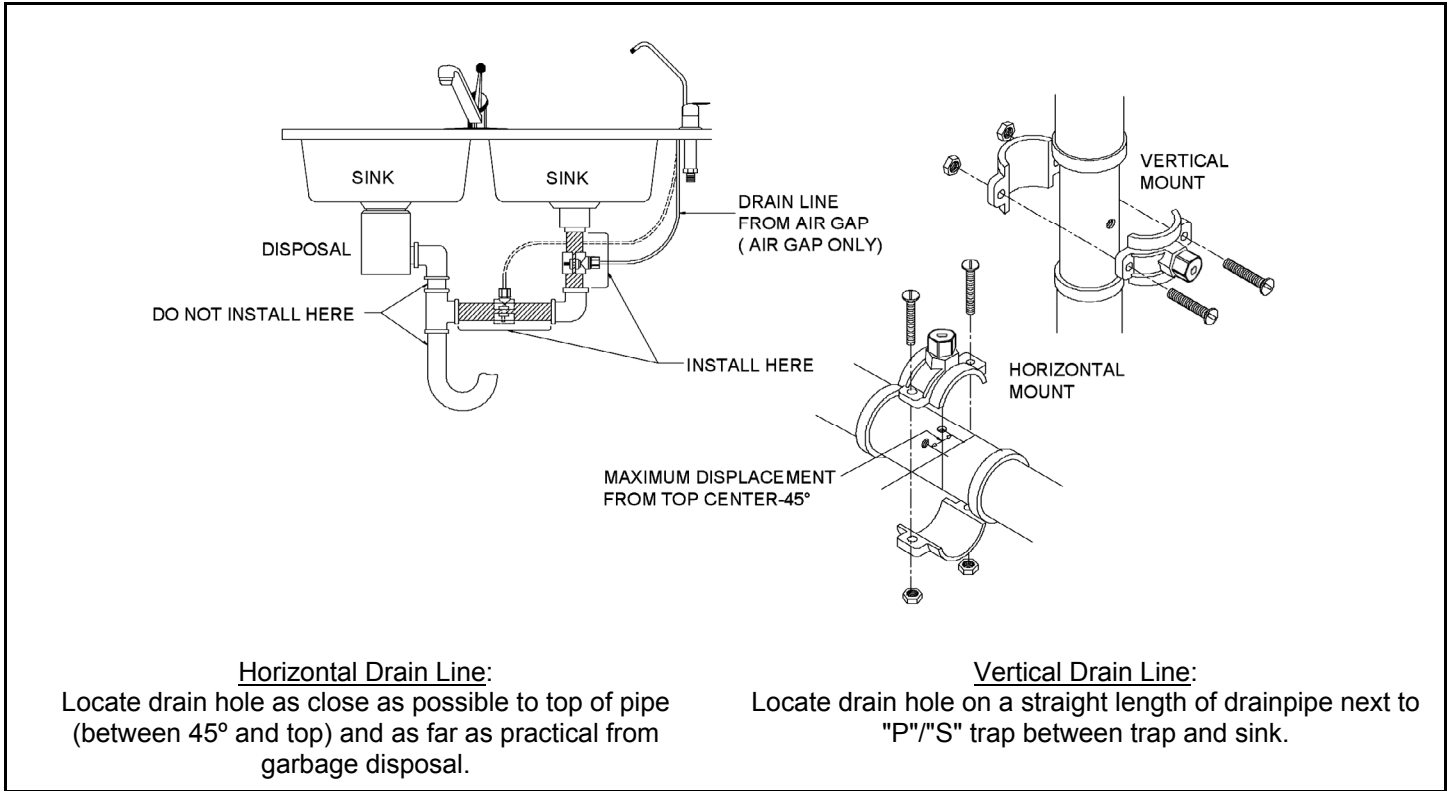
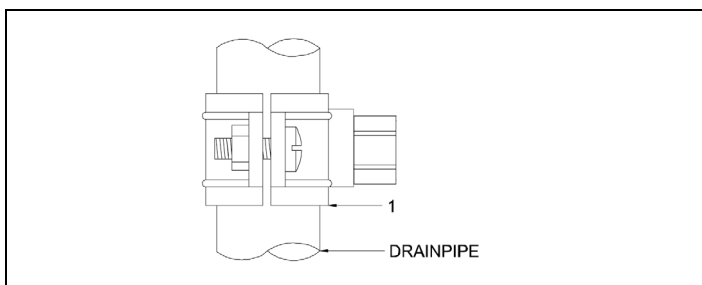

**Figure 4:** Drain Hole Location and Installation, Air Gap Faucet

1. Select a location for drain hole based on type of sink and orientation of drain line (Figure 4).

**NOTE:** Item callouts refer to Figure 5 unless noted otherwise.

2. Position drain outlet saddle (Item 1) on drainpipe. Allow adequate space for drilling operation.
3. Tighten saddle bolts evenly on both sides. Avoid over-tightening.
4. Using opening in drain saddle outlet as a guide, drill a 3/8" to 7/16" diameter hole in drainpipe. Clean any debris out of drain saddle connection.



Item	Description	Part No.
1	Drain Saddle, Air Gap, 3/8" Connection	92160

**Figure 5:** Drain Outlet Assembly

### Installation of Ball Valve Assembly on Plastic Storage Tank

The ball valve and quick connect adapter must be installed on the RO storage tank.

1. Install the 1/4" x 3/8" male connector onto the ball valve. Tighten the fitting very gently until it is snug. Be very careful not to over-tighten or the threads may strip.
2. Tighten the ball valve assembly onto the RO storage tank. Tighten the fitting very gently until it is snug. Be very careful not to over-tighten or the threads may strip.
3. **IMPORTANT**-Make sure to install the 'INSERT' in the 3/8" tubing before tightening the nut of the ball valve.

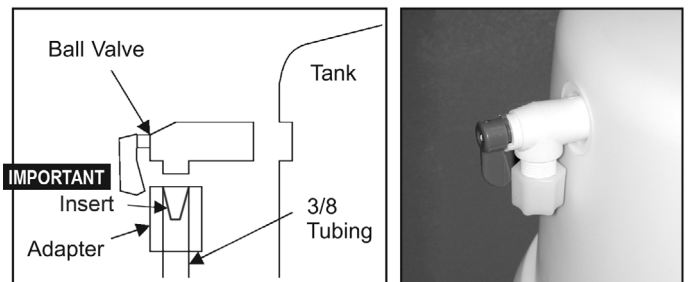

## PRODUCT WATER FAUCET SITE PREPARATION

Refer to Faucet Installation Instructions (Page 6) for site location and mounting hole specifications.

Primary considerations for site selection are convenience of use and an open area under sink. An existing 7/8" Sink Hole will also accommodate metal faucets with air-gap connections. Always check underside of selected location for obstructions.

### PORCELAIN/ENAMEL OVER STEEL OR CAST IRON SINKS

1. **CAUTION:** A heavy duty, variable speed drill motor with a spring-loaded porcelain drill set (Figure 6) is strongly recommended for this procedure.

**CAUTION:** The plastic sleeve supplied on pilot drill (Figure 6.A) is to be positioned on drill bit against drill chuck. This prevents chuck from contacting porcelain after pilot hole has been completed.

**NOTE:** Practice on discarded sinks to familiarize yourself with operation of porcelain cutter kit.

Using carbide tipped bit with plastic sleeve (Figure 6.A.), drill pilot hole completely through porcelain and metal underneath.

2. **CAUTION:** Avoid high motor R.P.M. during initial penetration of porcelain, as high drill speed will cause excessive chipping.

Place spring-loaded porcelain saw (Figure 6.B.) into drill chuck. Make sure pilot guide is inserted tightly. Insert pilot guide into pilot hole. Push down gently on drill motor to apply light pressure to porcelain surface. Start drill motor turning as slowly as possible.

After initial cut has started, motor speed may be gradually increased. The cut may require three to four minutes to complete. Going faster could result in excessive chipping. Be sure a complete ring has been cut through porcelain to material underneath.

3. Place finish hole saw (Figure 6.C.) into drill chuck. Make sure pilot guide is inserted tightly. Insert pilot guide into pilot hole. Begin cut using a slow speed and light pressure until porcelain (inside ring cut in Step 2) has been penetrated to material underneath.
4. Remove saw from hole and clean all debris from porcelain surface. Re-insert saw into hole and cut through remaining material.
5. Installation hole is ready, install faucet.

### TILE COUNTER TOP

1. Follow procedures detailed in section labeled "Porcelain/Enamel Over Steel" (substitute "tile" for "Porcelain" in instructions).

### STAINLESS STEEL SINK

1. Use a center punch to make a small indentation to mark center of desired location.
2. Drill a pilot hole with a 1/8" metal drill bit, then enlarge hole with a 3/8" metal drill bit.
3. Complete hole size by using a 1 1/4" chassis punch.
4. Installation hole is ready, install faucet.

#### A. PILOT DRILL

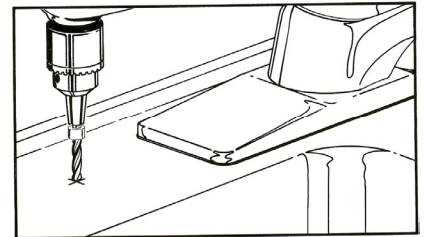

#### B. SPRING LOADED PORCELAIN SAW

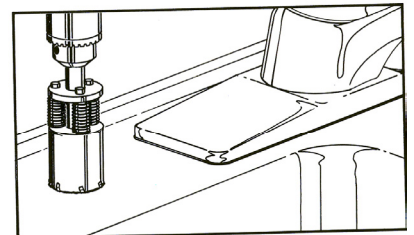
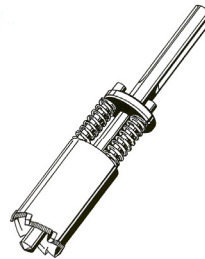

#### C. FINISH HOLE SAW

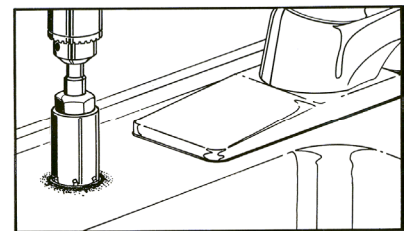
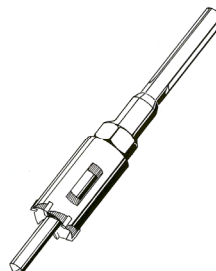

Figure 6

# METAL PRODUCT WATER FAUCET INSTALLATION AND SYSTEM CONNECTIONS

Install faucet on flat surface at least 2" in diameter. Unused 1 1/4" hole is ideal. Steps unique to a specific configuration are so noted. All other steps are common to either configuration.

## New Faucet Installation

Refer to Faucet Site Preparation, Page 5.

## Replacement Faucet Installation

Verify size of existing hole is 1 1/4".

**NOTE:** Item callouts refer to Figure 7 unless noted otherwise.

1. **Air Gap Only:** Verify faucet body, metal base washer, and rubber base washer are in place above sink (Items 1, 3, and 2).
2. **CAUTION:** Flow Restrictor (FLR) is installed inside the 1/4" red tubing on the end with the label. DO NOT TRIM THE END OF THE 1/4" FLR RED TUBING THAT INCLUDES THE LABEL (See Figure 8).

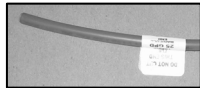

**Air Gap Only:** Install 3/8" red tubing from Installation Kit onto larger hose barb as shown in Figure 7.

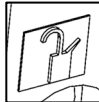
3. **Air Gap Only:** Connect the 1/4" FLR red tubing end with FLR label between the module red collet near symbol shown and the faucet:  

  - a. **Air Gap Only:** Insert the 3/8" red tube into the mounting hole.
  - b. **Air Gap Only:** Insert the 1/4" FLR red tubing upwards through mounting hole.
  - c. **Air Gap Only:** Position module in desired location. Trim the end of FLR tubing without label to desired length. Attach FLR tubing onto smaller hose barb as shown in Figure 7.
4. Lower faucet into mounting hole and place faucet over hole.
5. **Air Gap Only:** Install slotted washer, spacer, faucet washer, and nut onto faucet nipple below sink and snug them up (Items 4, 5, 6, and 7). Be sure to properly align faucet before tightening. Do not over tighten.
6. Install faucet connector (Item 8), packaged with faucet, onto faucet nipple. Install 3/8" blue tube into faucet connector.
7. Trim 3/8" blue tube to desired length. Install 3/8" blue tube into 3/8" blue collet located on side of module near symbol as shown.  

8. **CAUTION:** Red 3/8" tube connecting product water faucet to drain saddle must run vertically (or as closely as possible) with no sharp bends or loops (See Figure 4).

Connect loose ends of tubing as follows:

**Air Gap Only:** Connect 3/8" red tubing to 3/8" on drain saddle using compression nut. Refer to steps 2-4 in Polymer Tank Assembly for use of compression nuts.

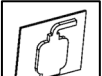
## Storage Tank Connection - Polymer Tank Assembly

**NOTE:** The following Instructions refer to Page IV, Figure 1.B., Item 1.

1. Hand-tighten the ball valve onto the RO storage tank.  
**CAUTION:** Do not over tighten ball valve as this may strip threads or compromise the "O" ring seal.
2. Slide compression nut over 3/8" white tubing.
3. Push 3/8" white tubing into the ball valve as far as possible.
4. While holding 3/8" white tubing in the ball valve, hand-tighten the compression nut onto the ball valve.
5. The basic installation is complete and system is ready for activation (See Page 10).
6. Connect 3/8" white tubing to the white collet on the module.  

## Storage Tank Connection - Metal Tank Assembly

**NOTE:** The following instructions refer to Page IV, Figure 1.B, Items 2 & 3.

**NOTE:** Refer to Page 2, Inter-Component Connections for instructions on how to install tubing.

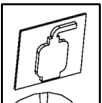
1. Install ball valve (located inside of master pack box) onto the 1/4" storage tank nipple. Use thread sealing tape to seal threads between ball valve and nipple.
2. Connect 3/8" white tubing between module (near symbol as shown) and storage tank shut-off valve.  

3. The basic installation is complete and system is ready for activation (see Page 10).

**NOTE:** With the storage tank empty, ensure the air-cell pre-charge is set to manufacturers instructions marked on tank. Use a hand power air pump to top up if necessary.

**WARNING:** Never use an air compressor to fill air cell of a reverse osmosis system storage tank.

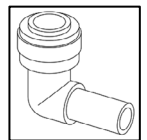
**NOTE:** Optional stem elbows have been supplied to allow installations with limited space to be simpler. Connect the stem elbow into the inlet, faucet, tank and drain parts as required before connecting tubing.

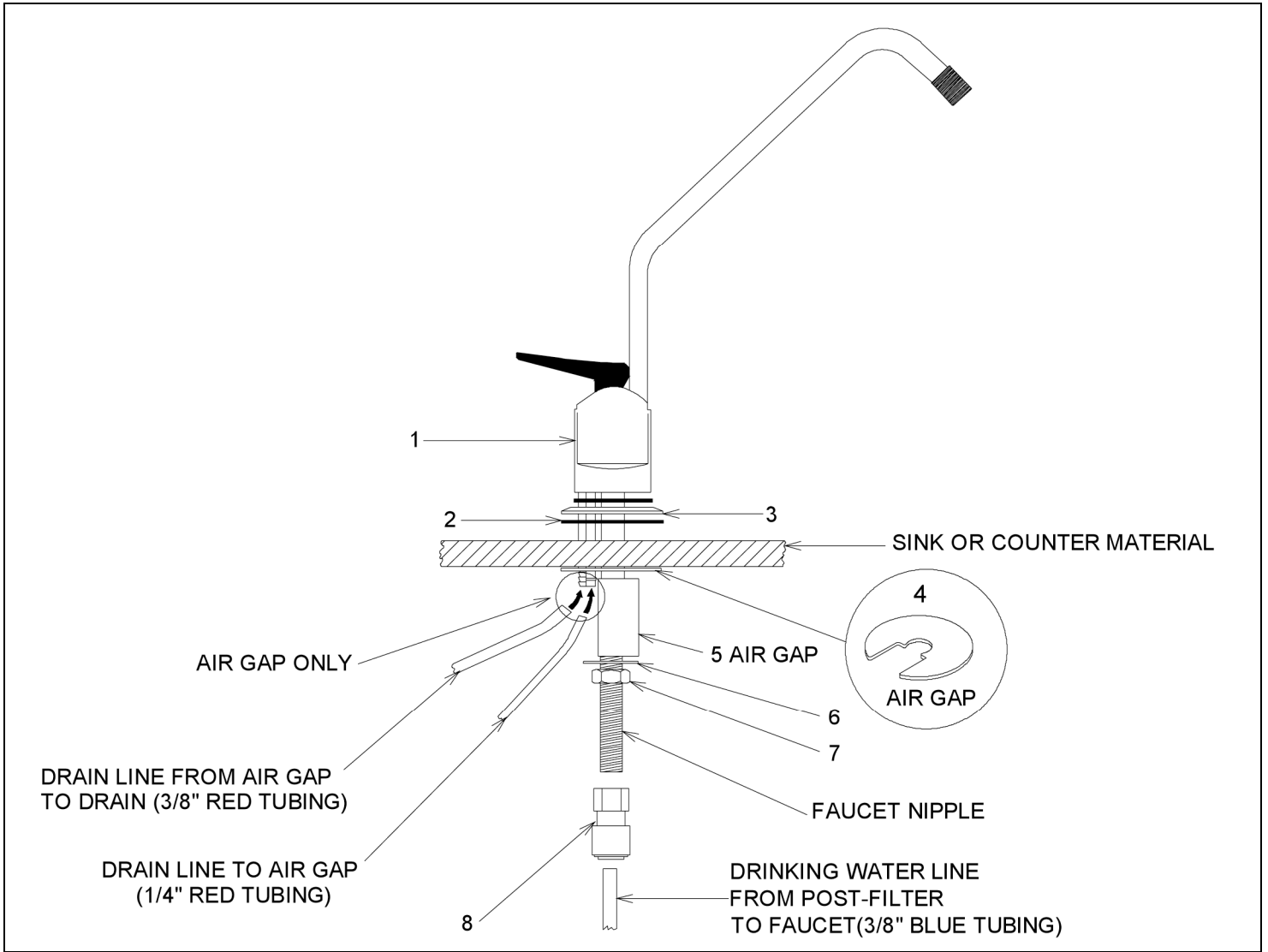



Description	Part No.
<b>Chrome Plated Metal Air Gap Faucet (USEPA Compliant, not available in California)</b>	<b>92192</b>

Item	Description
1	Body, Faucet
2	Faucet Base Washer, Rubber
3	Faucet Base Washer, Metal
4	Washer, Slotted (Air Gap, Slot Shape may vary)
5	Spacer, Faucet (Air Gap)
6	Washer, Faucet
7	Nut, Faucet
8	Connector, Faucet 3/8" x 7/16"

**Figure 7:** Chrome-Plated Metal Product Water Faucet Assembly

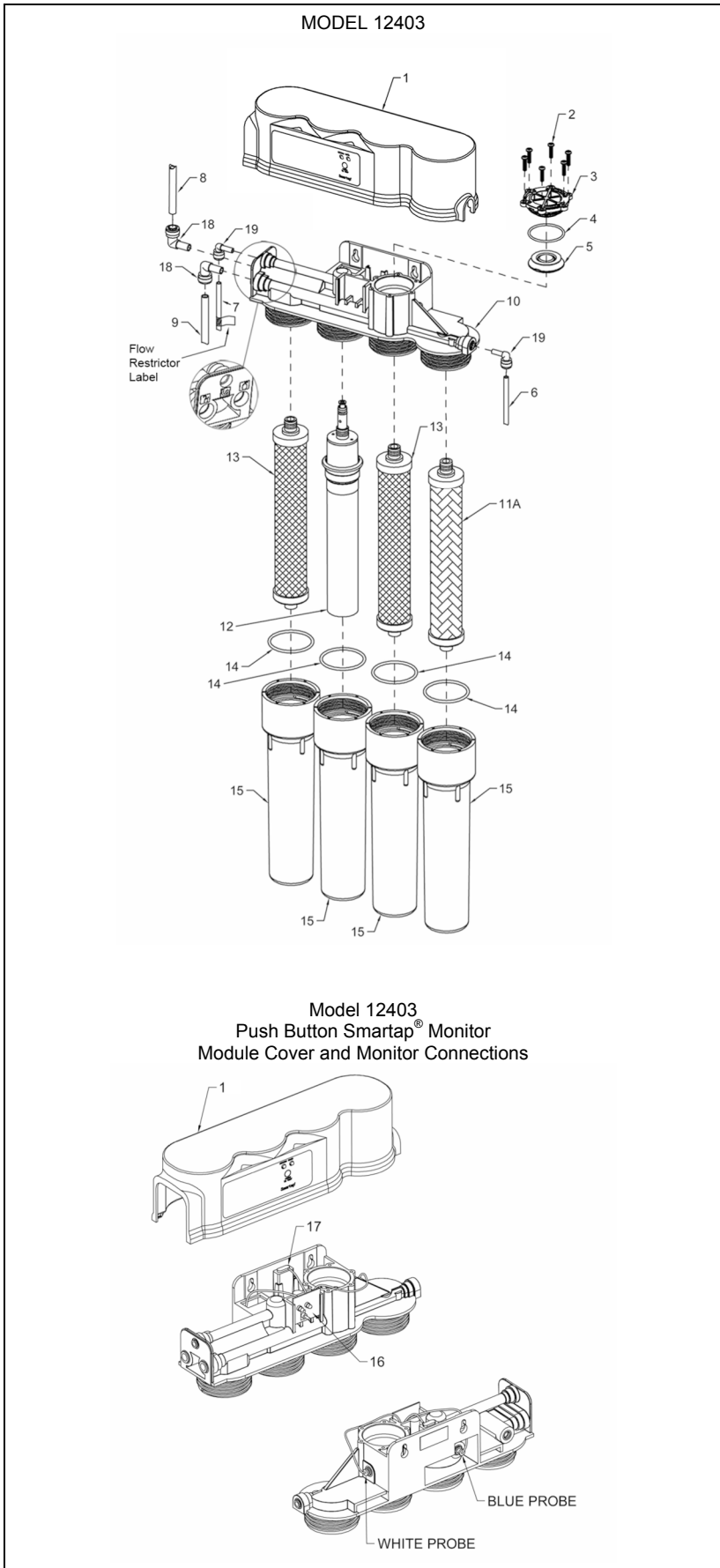

Item	Description	Part No.
1	Cover, 4-vessel Push Button Manifold †	20500127
2	Screw, inlet Valve Cover	32701038
3	Cover, Inlet Valve	20500126
4	"O" Ring, Inlet Valve Cover	34201024
5	Shut Off Assembly	40600010
6	Tubing, 1/4", White *	115200
7	Flow Restrictor, 1240 Series, Red	
	9 GPD	40600034
	25 GPD	40600040
	50 GPD	40600041
	75 GPD	40600042
8	Tubing, 3/8", Blue *	87600
9	Tubing, 3/8", White *	115207
10	RO, 4V Manifold, Assembled **	12402
11A	Cartridge, Sediment, 5 micron	41400008
12	Filter, Membrane Thin Film Composite	
	9 GPD, Yellow Casing Red Tape	33001071
	25 GPD, Yellow Casing Black Tape	33001068
	50 GPD, Yellow Casing White Tape	33001033
	75 GPD, Yellow Casing Blue Tape	33001056
13	Cartridge, Carbon AES, 10 micron	41400009
14	"O" Ring, Filter Housing	34201026
15	Housing, Filter	20500129
16	Circuit Board	40200132
17	Battery 9 volt	701085
18	Elbow, Stem, 3/8" *	33501071
19	Elbow, Stem, 1/4" *	33501064
n/s	Kit, O-Rings, Collets, QC, 1/4" & 3/8"	92166
n/s	Safety Clips 1/4"	92345
n/s	Safety Clips 3/8"	92346
<p>*Note: These parts are included with installation kit.  ** Includes Items: 2, 3, 4, 5.  n/s – not shown</p>		

**Figure 8:** Exploded Schematic, 12403 Model Series

†To obtain the correct replacement decal/label, contact your dealer.

## ACTIVATING THE SYSTEM

**CAUTION:** Make sure all water supply lines, drain lines, and fittings are secure and free from leakage.

1. Open source water supply valve. Close product water faucet. Check for leakage.
2. Turn tank valve one-quarter turn counter-clockwise to open valve (handle should be in line with tubing as it enters connection).
3. Confirm system is producing water. Module will be sending rinse water to drain.
8. Open product water faucet and let water flow until all air has been expelled from system.
9. Close product water faucet. In 30 minutes, check connections for leaks and correct if necessary.
10. Allow storage tank to fill overnight.

Icemaker/Extra point of use: Check connections on these supply lines for leaks.

**Optional Smartap® Water Quality Monitor  
Perform Steps 4 - 7**

4. Remove manifold cover if attached by gently lifting cover up and away from manifold.

**CAUTION:** Wiring within module cover connects monitor components. If wires, circuit board, or connections are damaged and/or wetted, monitor will not function.

5. **CAUTION:** Verify battery connector alignment before making connection (Figure 9).

Connect battery on manifold by pressing clip onto battery terminals.

6. Replace manifold cover by gently pushing cover onto manifold until it snaps into place.

7. Test battery connection by activating monitor. Press push button. If either indicator light illuminates, connection is good.

**NOTE:** Release button after light illuminates. Test is to confirm battery connection, not water quality.

**11. WARNING: DO NOT USE THE FIRST FULL STORAGE TANK OF WATER**

Discard (to drain) first full tank of water by opening product water (and extra point-of-use) faucet until water flow stops, then close faucet. This will flush sanitizing solution from system.

Icemaker: Let tray/bin fill with ice cubes. Discard all ice cubes. This flushes sanitizing solution from lines to icemaker.

12. System is ready to use. Should there be any aftertaste or odor to water or ice cubes, repeat Steps 10 and 11.

**DO NOT USE THE FIRST STORAGE TANK OF WATER**

Allow storage tank to fill overnight. Dispense this water to drain.

This process removes factory-installed sanitizing solution from the entire system and sends it to drain.

This process also sanitizes fittings and tubing used during installation.

**MAINTENANCE PROCEDURE PREPARATION**

**RECOMMENDATIONS**

HAVE ALL EQUIPMENT AND REPLACEMENT COMPONENTS ON HAND AND READY BEFORE BEGINNING PROCEDURE.  
A CLEAN WORK AREA AND EQUIPMENT ARE ESSENTIAL TO PROPERLY CLEAN AND/OR SANITIZE THE SYSTEM.  
(i.e., CLEAN HANDS, TOOLS, WORK SURFACE, AND CONTAINERS)

**EQUIPMENT NEEDED**

Safety glasses Rubber gloves, sanitary Wash Cloth, Clean and Lint-free Liquid dish soap	Household bleach - Unscented Only (5 1/4% sodium hypochlorite) Plastic storage bag Manual Air Pump	Plastic bucket Plastic bowl "O" ring Lube FDA Approved
--	---	--

## CLEANING, SANITIZING, AND CARTRIDGE REPLACEMENT PROCEDURE

1. Mix mild cleaning solution of dish soap and clean potable water in plastic bowl.
2. Empty storage tank and relieve system pressure. Verify tank valve is open. Close feed water supply valve and open product water faucet.  
**Ice maker:** Transfer ice cubes from bin/tray to clean freezer container for storage until procedure is done.
3. **CAUTION:** Use air hand pump to avoid damaging tank. Verify product water valve is open before proceeding.  
Check product water storage tank air pre-charge using a low-pressure gauge (e.g. 0 -15 or 0 – 30 psi). Air valve is located on tank base. Pre-charge should be 55 kPa (8 psig) with tank empty and tank valve open.

4. **CAUTION:** Do not attempt to remove filter housings until water flow stops. This reduces pressure inside the system so housings may safely be removed.  
**CAUTION:** Additional point-of-use devices (i.e., icemakers) may use filters along their supply line. Remove any filter or treatment device installed between module and device before proceeding.  
Remove each filter/membrane housing by turning it counter-clockwise. Remove each filter cartridge as its housing is removed. Discard filters.

IF MEMBRANE IS PERFORMING SATISFACTORILY:  
Proceed to Step 5.

IF MEMBRANE IS DEPLETED OR FOULED:  
Discard it and go to Step 7.

5. **CAUTION:** Use sanitary rubber gloves for this procedure to avoid contaminating sanitizing solution, filters, or membrane. Wear gloves whenever cleaning/ sanitizing system components or handling new filter/membrane cartridges.  
Clean membrane outer wrap with washcloth and cleaning solution. Do not immerse membrane in solution. Do not scrub membrane wrap with abrasive cleaners. Rinse membrane well with clean potable water.
6. Place membrane into clean plastic bag, close bag.
7. Remove filter/membrane housing "O" rings and wash them with cleaning solution. Rinse them well with clean potable water. Inspect them for damage (i.e., nicks, scratches). Replace damaged "O" rings.
8. **CAUTION:** Do not get Smartap® Water Quality Monitor electronics, wiring, or connectors wet.  
Clean filter housings and manifold ports, inside and outside, with washcloth and cleaning solution. Do not use abrasive materials.

9. Rinse manifold/housings with clean potable water.
10. Inspect manifold and filter housing "O" ring groove area for damage (i.e., nicks or scratches). Replace damaged components.
11. Place a small amount of "O" ring lubricant over surface of filter/membrane housing "O" ring. Install "O" ring into filter housing groove.

TO SANITIZE THE SYSTEM: Complete Steps 12-34.

TO INSTALL FILTERS: Complete Steps 19-34.

**WARNING: WEAR SAFETY GLASSES WHILE PERFORMING THIS PROCEDURE.**

**READ "WARNINGS" INFORMATION ON BLEACH CONTAINER BEFORE USING CONTENTS.**

**HANDLE SANITIZING SOLUTION CAREFULLY. AVOID CONTACT WITH UNPROTECTED AREAS.**

12. **CAUTION:** Excessive concentrations of bleach will damage plastic and rubber components. Rinse all parts that contact bleach thoroughly with clean potable water.

Mix sanitizing solution of 1.5 ml (1/3 teaspoon) of household bleach and 3.8 L (1 gallon) of clean, potable water in the bucket. Mix solution well.

13. **CAUTION:** Tighten filter housings by hand only. Do not use tools as they will over-tighten and damage housings. Take care not to cut or pinch o-rings.

Add 236 ml (one cup or 8 oz.) of sanitizing solution to each filter housing and install them onto the manifold (do not install filters or membrane at this time). Tighten each filter housing by hand only.

14. Slowly open source water supply valve.
15. Open product water faucet. Close faucet as soon as water begins to flow from spout.
16. Wait 5 minutes, then close source water supply valve.
17. Wait 25 minutes, then open product water faucet and let water flow to drain.
18. **CAUTION:** Do not attempt to remove filter housings until water flow stops. This reduces pressure inside the system so housings may be removed safely.  
Remove filter housings and dispose of water. Rinse filter housings and manifold ports thoroughly with clean potable water.

## CLEANING, SANITIZING, AND CARTRIDGE REPLACEMENT PROCEDURE

19. **CAUTION:** Do not remove protective plastic bag from replacement filter/membrane cartridges until so instructed.

Install "O" rings into filter housings. Open top of filter bag enough to expose filter cap and "O" ring grooves. Place a small amount of "O" ring lubricant on surface of each "O" ring.

20. **CAUTION:** Tighten filter housings by hand only. Do not use tools as they will over-tighten and damage housings. Take care not to cut or pinch o-rings.

**CAUTION:** Refer to Figure 8 for location of each cartridge.

Install filter and membrane cartridges. Hold cartridge by its protective plastic bag and insert cartridge into manifold turning it 1/4 turn as it enters the port. Slide bag from cartridge and discard. Replace each filter housing as each cartridge is installed.

21. Turn feed water valve slowly to open position.
22. Confirm system is producing water. Unit will be sending rinse water to drain.

### Optional Smartap Water Quality Monitor

TO REPLACE BATTERY: Perform Steps 23 – 29

**NOTE:** Replace battery with a new alkaline 9-volt battery.

23. **CAUTION:** Wiring within module cover connects monitor components. If wires, circuit board, or connections are damaged and/or wetted, monitor will not function.

Remove module cover by gently lifting manifold cover up and away from manifold body.

24. Disconnect battery. The battery connection is a snap type connector (Figure 9).
25. Remove battery by sliding it out of its holder.
26. Slide new battery into its holder.
27. **CAUTION:** Verify battery connector alignment before making connection (Figure 9).
- Connect battery by pressing clip onto battery terminals.
- NOTE:** Release button immediately after light illuminates. Test is to confirm battery connection, not water quality.

28. Test battery connection by activating monitor. Press push button. If an indicator light illuminates, connection is good.

29. Replace manifold cover by gently pushing manifold cover onto manifold until it snaps into place.

30. Open product water faucet. Let water flow until all air has been expelled from the system.

31. Close product water faucet. Wait 30 minutes, check connections for leaks, and correct if necessary.

Icemaker/Extra point of use: Check lines for leaks.

32. Allow storage tank to fill overnight.

33. **WARNING: DO NOT USE THE FIRST FULL STORAGE TANK OF WATER**

Discard (to drain) first full tank of water by opening product water faucet until water flow stops, then close faucet. This flushes sanitizing solution from system.

Icemaker: Let tray/bin fill with ice cubes. Discard all ice cubes to drain. This flushes sanitizing solution from lines to icemaker. Replace delivery device filter (if applicable).

34. System is ready to use. Should there be any after taste or odor, drain storage tank and repeat Steps 32 and 33.

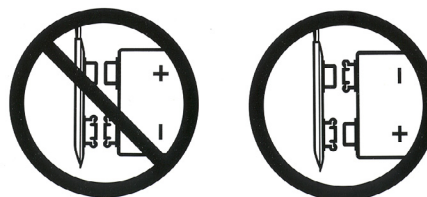

**Figure 9:** Smartap® Battery Connections

### **DO NOT USE THE FIRST FULL STORAGE TANK OF WATER**

Allow reservoir to fill overnight.

Dispense this water to drain.

This process removes sanitizing solution from system, sanitizes fittings and tubing, and sends solution to drain.

**TROUBLESHOOTING INDICATORS AND COMMON SOLUTIONS**

**Table 5**

<b>WATER VOLUME AND QUALITY</b>		
<b>Symptom</b>	<b>Condition</b>	<b>Action</b>
No product water.	Water supply is turned OFF.	Turn water ON.
Not enough product water.	Low water pressure. Water supply is blocked. Storage tank valve is closed. Storage tank is depleted.  Clogged Pre-filter cartridge(s). Storage tank air pressure charge is low.	Check source water line pressure. Clear restriction. Open storage tank valve. Increase product water storage capacity and/or install membrane and flow restrictor with higher output rating. Replace Pre-filter cartridge(s). Empty water from storage tank (product water valve must remain open while adjusting pressure) and adjust pressure to 55 kPa (8 psig).
System does not shut off.	Shut-off valve is not closing.	Contact your local Dealer.
No drain water.	Clogged Flow Restrictor.	Replace Flow Restrictor.
Water has offensive taste and/or odor.	Carbon post-filter is depleted.  Membrane depleted or fouled.  Sanitizer not flushed out.	Drain storage tank, sanitize system, and replace carbon post-filter cartridge.  Smartap® Monitor reads yellow, or if TDS test is unsatisfactory, drain storage tank, sanitize system, and replace membrane.  Drain storage tank and let it refill overnight.
<b>LEAKAGE AND NOISE</b>		
<b>Symptom</b>	<b>Probable Cause</b>	<b>Solution</b>
Leak at fitting.	Tubing not pushed completely into fitting. Defective tube.	Push tube into fitting past "O" ring seal. Cut damaged area from tube or replace tube (See Figure 2).
Leak at filter housings.	"O" ring has not seated properly.  "O" ring has nicks or scratches.	Remove "O" ring and inspect "O" ring groove for debris. Clean groove, lube, and reseal "O" ring.  Replace "O" ring.
Leak from air gap in faucet.	Restricted drain tube. Obstructed hole in drain clamp Tubing from air gap to drain is routed incorrectly.	Clear restriction. Remove obstruction. Reroute tubing so tubing runs vertically with no sharp bends or loops (see Figure 4).
Noise from system and/or faucet air gap.	Trapped air in system. Typical of new system or as a result of filter changes.	Nothing, system usage will purge trapped air.
<b>PUSH BUTTON ACTUATED SMARTAP® WATER QUALITY MONITOR</b>		
<b>Indication</b>	<b>Condition</b>	<b>Action</b>
Green Light.	System operating normally.	None.
Yellow Light.	Low or non-usage.  Membrane depleted or fouled.	Draw enough water from product water faucet to get system into making water. Wait 10 minutes, test.  Clean and sanitize system. Replace membrane.
Dim or No Light.	Battery voltage low.	Replace Battery.

## LIMITED WARRANTY

Subject to the conditions and limitations described below, WaterGroup warrants its Model 12403 Series Reverse Osmosis Drinking Water Treatment Systems (excluding membrane, cartridge filters and battery), when installed in accordance with WaterGroup specifications, to be free from defects in materials and workmanship under normal use within the operating specifications for a period of two (2) years from the date of purchase (with bill of sale) or 2.5 years from product date code, whichever occurs first. WaterGroup also warrants the Smartap<sup>®</sup> Water Quality Monitor to be free from defects in materials and workmanship under normal use within the operating specifications for a period of five (5) years from the date of purchase. This warranty shall apply to the original end-user of the system only.

Other than the membrane, cartridge filters and battery, any part found defective within the terms of this warranty will be repaired or replaced by WaterGroup. If any part is found defective, WaterGroup also reserves the right to replace the drinking water appliance with a comparable WaterGroup drinking water system of equal or greater quality. You pay only freight for repaired or replaced parts from our factory and local dealer charges, including but not limited to labor charges, travel and transportation expenses and handling fees.

This warranty shall not apply to any part damaged by accident, fire, flood, freezing, Act of God, bacterial attack, membrane fouling and/or scaling, sediment, misuse, misapplication, neglect, alteration, installation, or operation contrary to our printed instructions, or by the use of accessories or components which do not meet WaterGroup specifications. If the drinking water system is altered by anyone other than WaterGroup the warranty shall be void.

ALL IMPLIED WARRANTIES, INCLUDING WITHOUT LIMITATION WARRANTIES OF MERCHANTABILITY AND FITNESS FOR PARTICULAR PURPOSE, ARE LIMITED TO THE DURATION OF THE PERIOD SPECIFIED ABOVE FOR THE PARTS DESCRIBED IN THIS LIMITED WARRANTY.

As a manufacturer, we do not know the characteristics of your water supply. The quality of water supplies may vary seasonably or over a period of time. Your water usage may vary as well. Water characteristics can also change if the drinking water appliance is moved to a new location. For these reasons, we assume no liability for the determination of the proper equipment necessary to meet your requirements, and we do not authorize others to assume such obligation for us. Further, we assume no liability and extend no warranties, express or implied, for the use of this product with a non-potable water source or a water source which does not meet the conditions for use as described in this Owners Guide.

WATERGROUP'S OBLIGATIONS UNDER THIS WARRANTY ARE LIMITED TO THE REPAIR OR REPLACEMENT OF THE FAILED PARTS OF THE DRINKING WATER SYSTEM, AND WE ASSUME NO LIABILITY WHATSOEVER FOR DIRECT, INDIRECT, INCIDENTAL, CONSEQUENTIAL, SPECIAL, GENERAL OR OTHER DAMAGES, WHETHER FROM CORROSION OR OTHER CAUSES.

Some states do not allow limitations on how long an implied warranty lasts, so the above limitations may not apply to you. Similarly, some states do not allow the exclusion of incidental or consequential damage, so the above limitation or exclusion may not apply to you. This warranty gives you specific legal rights, and you may have other rights that vary from state to state.

### WaterGroup Inc.

193 Osborne Road  
Fridley, MN  
U.S.A. 55432

8291 Milliken Ave.  
Rachno Cucamonga, CA  
U.S.A. 91730

### WaterGroup Companies Inc.

580 Park Street  
Regina, SK  
Canada, S4N 5A9

265 Industrial Road  
Cambridge, ON  
Canada N3H 5N3

For parts and service, contact: